

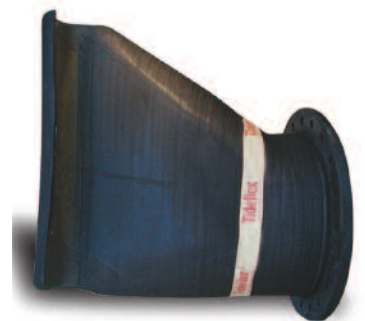

Tideflex[®]
Technologies

Check Valves and Engineered Systems for
Water Mixing, Aeration and Effluent Diffusers



The Tideflex® Check Valve:

For **RELIABLE** Backflow Protection!



In 1984, the U.S. Environmental Protection Agency commissioned us to develop and test an alternative to flapgate valves, stating that, “Increasing the reliability and performance of tidegates has a beneficial impact on the general pollution abatement program for the nation’s waterways.” The elastomer “duckbill” Tideflex® Check Valve was specifically designed to eliminate the operational and maintenance problems associated with flapgate check valves, including corrosion of mechanical parts, freezing open or shut, warping and

clogging due to trapped debris. The EPA rigorously tested the Tideflex® valve for two years and found that Tideflex® showed significant improvement over flapgate valves in terms of leakage inflow, entrapment of debris, capability to self clean and susceptibility to marine fouling. Today, hundreds of thousands of Tideflex® valves are installed and performing reliably worldwide.

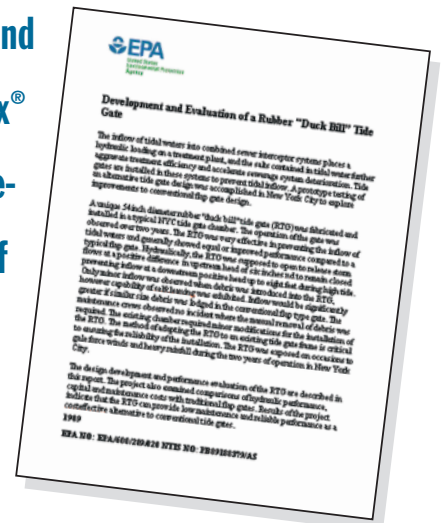

The TF-1 Check Valve

20 Years Of Proven Performance And Reliability

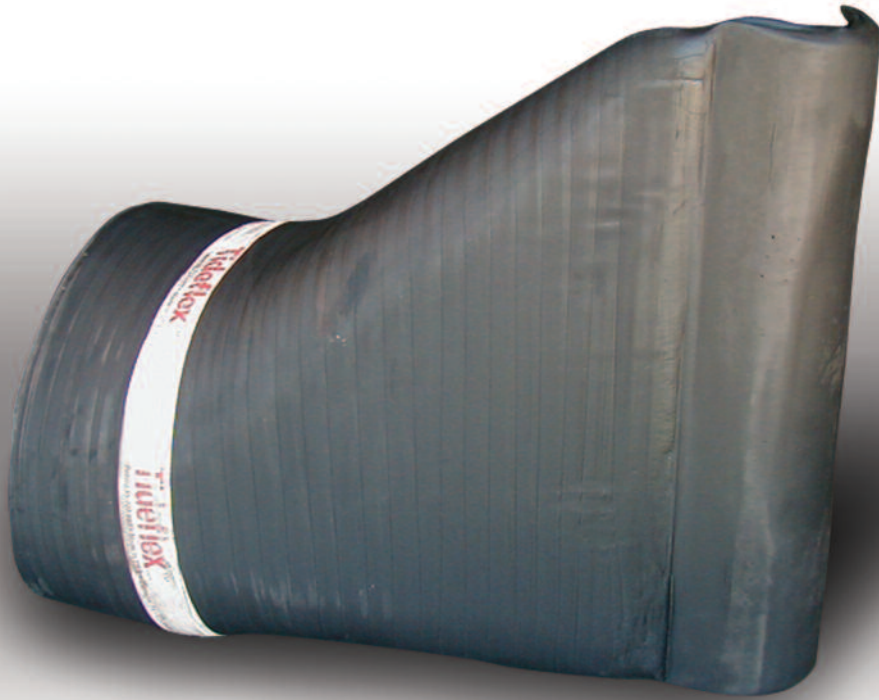

The TF-1 is the Latest Innovation in Tideflex® Check Valve Technology

Twenty years of proven field operation, research, development and continued engineering enhancements have combined to make the TF-1 today's most reliable check valve. The bill is formed into a curve that returns to a closed position every time, achieving the tightest possible seal for backflow applications, particularly at low flow rates.

The eccentric flat-bottom design allows installation where the invert of the pipe is close to the floor. The stronger engineered spine provides long-term performance while handling long-term water weight. When you specify the patented Tideflex® TF-1 Curved Bill Check Valve, you are guaranteed a proven record of maintenance-free backflow prevention.



Engineered Features

- ▶ Eccentric flat-bottom design
- ▶ No moving or mechanical parts
- ▶ 100% elastomer construction
- ▶ Curved bill design enhances sealing
- ▶ Low headloss for low-lying areas
- ▶ Sensitive enough to open with as little as 1" of water pressure
- ▶ Custom-built to your flow specifications
- ▶ Cost-effective, reliable replacement for traditional flapgates
- ▶ Silent, non-slamming
- ▶ Self-draining, eliminates standing water

3

Principle of Operation

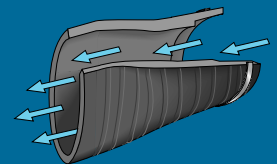

The Tideflex® Check Valve opens with positive pressure.

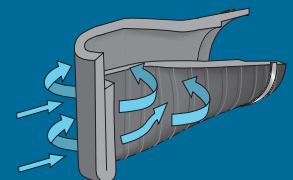

Reverse pressure seals the curve bill of the Tideflex® to prevent backflow.

Pumping Stations

Large stormwater pumping stations use Tideflex® Check Valves to ensure that tailwater does not backflow into stormwater catchments.

The rubber construction of the Tideflex® valve is resistant to saltwater, and low headloss characteristics are ideal for low-lying areas.



Sewer Systems

Tideflex® valves prevent floodwaters from surcharging sewer lines and washing raw sewage into streets and basements.



Effluent Discharge

Tideflex® valves protect discharge lines from rising waters that can flood and surcharge a treatment plant. Ecosystems are also protected by the Tideflex® Check Valve's ability to diffuse effluent and prevent backflow.



Tide Techn Engine Reli Perfor

Airport/Highway Runoff

Tideflex® valves are used extensively for large surface water areas that require backflow prevention, such as airport runways, highways and parking lots. Tideflex® provides an ideal solution where regulations require treatment of toxic hydrocarbons from runoff.

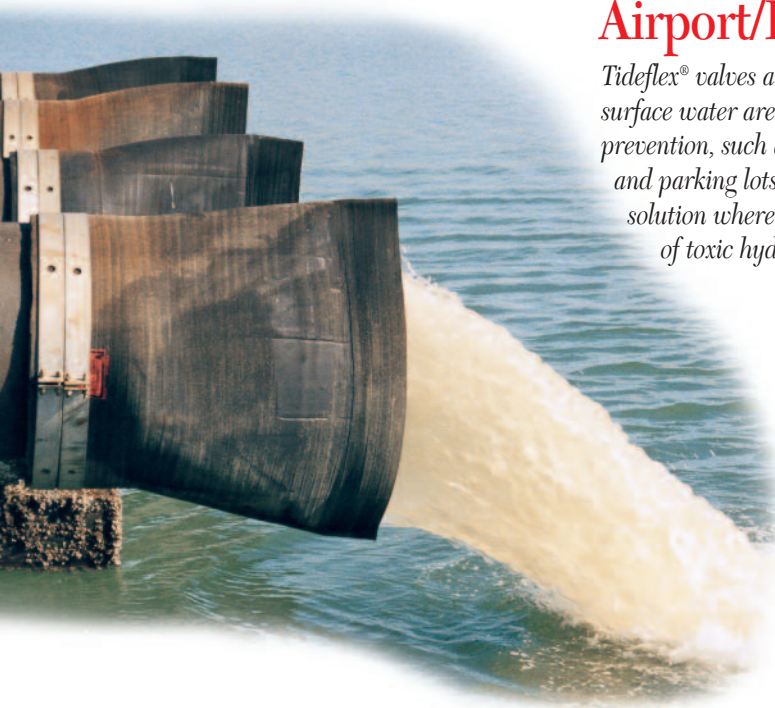

CSO/SSO Systems

Combined sewer and sanitary sewer overflow systems use Tideflex® valves to prevent receiving water from backflowing to the sewage treatment plant. The new flat-bottom TF-1 is designed for CSO/SSO manhole installations.





Stormwater Discharge

Tideflex® Check Valves are the first choice of coastal and inland municipalities for stormwater systems. Tideflex® valves discharge with 1" of differential pressure, which maximizes pipeline storage capacity.



flex®
ology:
ered for
able
mance.

Site Drainage

Residential areas, office parks and commercial shopping centers use Tideflex® valves to allow the free flow of stormwater and to prevent backflow and flooding from canals, streams and rivers.



Flood Control Systems

Tideflex® valves are used extensively for flood control. They can sit inactive for years and still be ready to provide backflow protection in the event of a flash flood. Typical applications include retention basins, levees, locks and dams, fish bypass systems, city stormwater collection systems, highways, parking lots, airport runways and large industrial and office complexes.





Floatables Control

Tideflex® valves are used as part of a floatables control strategy to prevent accumulated debris from being washed out of collection areas by floodwaters.



Retention Ponds

Tideflex® valves are used on retention ponds and lagoons because they often are inactive for long periods of time. Unlike metal flapper valves the Tideflex® valves will not rust or corrode.



Tide Engine Mainten Operati Enviro

6

Marinas

Marinas and discharge lines can peacefully coexist because the rubber construction of the Tideflex® valve is quiet, safer to boat hulls than a rigid metal valve and resistant to spills such as oil and fuel.



Levees

Low-lying areas protected by levees depend on Tideflex® valves to prevent high water levels from backflowing from the river and allow stormwater to freely drain into the river. The low cracking pressure of the valve allows easy draining even when little difference in elevation exists.



Groundwater Relief

Inground storage basins use Tideflex® valves to relieve pressure from groundwater. The valves allow groundwater to enter the basin while preventing stored fluid from escaping. Tideflex® valves can be fitted to concrete basins, steel tanks and even geotextile liners.

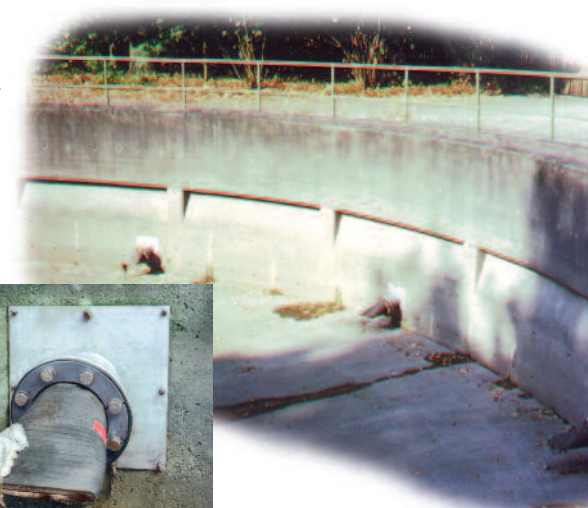



Coastal Discharge

Rocky areas cause problems for a flapgate valve because stones become lodged in the valve, preventing it from closing fully, or pile up in front of the valve, preventing it from opening. Tideflex® valves installed in these areas are more reliable.

Odor Control

Offending odors from sewer systems can be prevented from escaping with lightweight Tideflex® valves while water is still allowed to discharge when needed.



flex®: ered for ance-free on in Any nment!

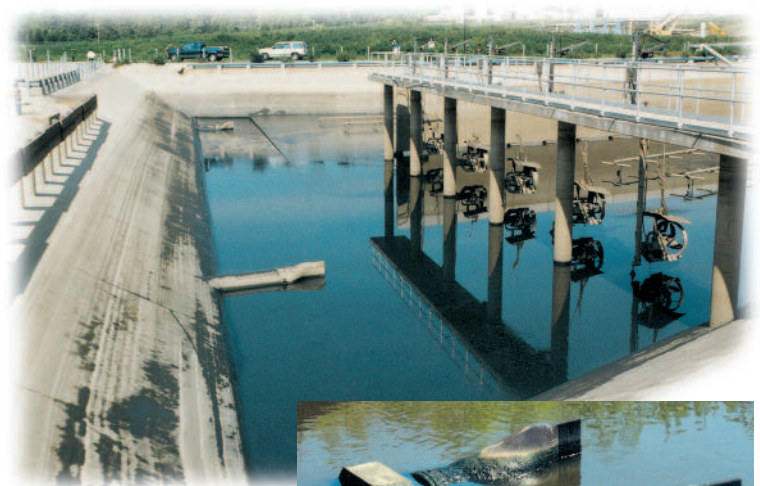

Flow Equalization Basins

Tideflex® valves are used to prevent backflow from one stage of pretreatment to another. The all-rubber construction outlasts any metal valve in raw sewage, and the operation of the valve is not affected by debris such as plastic bags, twigs or leaves.



Residential

Tideflex® Check Valves have become frequently specified for commercial and residential areas where dependable backflow prevention is necessary. The valve is maintenance-free. Passive and silent operation are key benefits.



Wetlands

Tideflex® valves prevent hazardous spills, runoff from mining operations, leachate from landfills and saltwater from infiltrating protected wetland areas.



Slip-on

Where an exposed length of pipe is available at the discharge end of a pipe, the cuff of the Tideflex® valve is built to match the outside diameter of the pipe, and the valve is easily slipped into place. Band clamps are used to secure the valve.

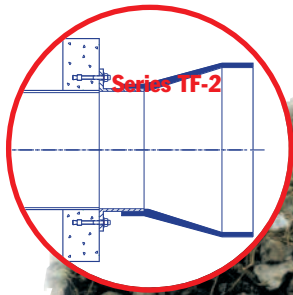
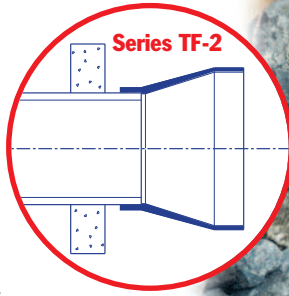

8



Thimble Plate

Where the pipe terminates flush with a headwall, a plate is secured over the opening, and the Tideflex® valve is slipped onto the pipe thimble. This mounting can also be used to cover square culverts and oversized openings.

The Tideflex Engine For Piping

Integral Rubber Flange

An integral rubber flange allows direct connection to flanged-end pipe or headwalls and seawalls.

Flanges can be ANSI, DIN or special drill patterns, including square and rectangular. Backup rings are provided, and gaskets are not required.

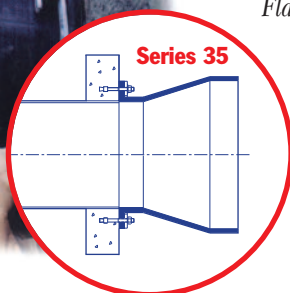



Grouted Pipe Stub

A pipe stub slightly smaller than the inside diameter of the discharge line can be grouted into the end of the pipe. The Tideflex® valve is then slipped onto the stub, eliminating the need to drill into the headwall or seawall.

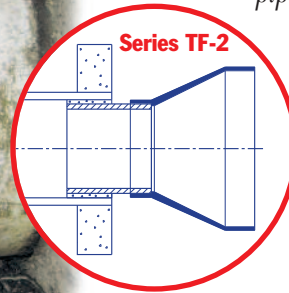

There is a
Tideflex® Valve
 engineered
 for every
 system!

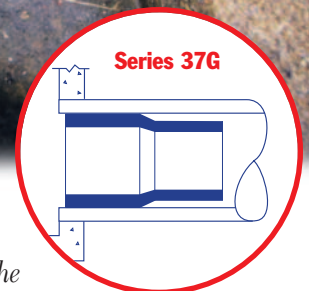
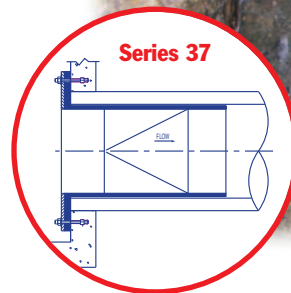
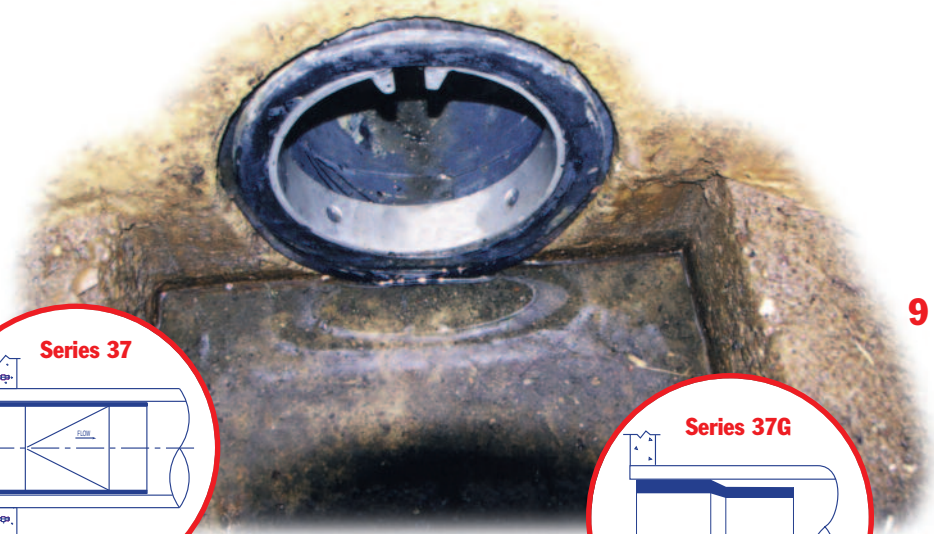

Slip-inside Pipe

Commonly used in CSO systems, the Tideflex® Series 37 is slipped into the inlet end of a pipe, and the integral rubber flange secures the valve to the manhole wall with a retaining ring. If there is not sufficient room below the invert of the pipe, the Series 37G is installed inside the pipe and fastened with internal expansion clamps.

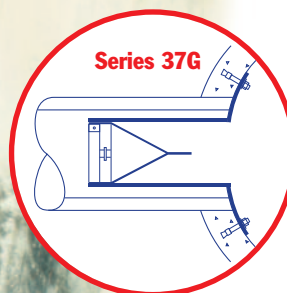

Thimble Insert

A thimble insert is used to add a Tideflex® valve to the influent pipe of a manhole whenever clearance is not sufficient to allow the valve to protrude into the manhole. The assembly is inserted into the influent pipe and anchored to the manhole wall. This assembly can also be used at the end of a pipe where protrusion into a waterway is not desired.

Series TF-1

- ▶ Ideal for installations when invert is close to the floor
- ▶ Minimal bottom clearance required
- ▶ Engineered with a curved bill
- ▶ Custom designed for various backpressure ratings
- ▶ Strong spine designed for long term water weight

Materials of Construction:

Neoprene, Hypalon®, Buna-N, EPDM, Viton®

Mounting Bands:

304 or 316 Stainless Steel

The TF-1 was engineered through extensive research and field experience. Engineered designed features of the TF-1 include:

- A strong engineered spine provides long-term performance while handling long-term water weight.
- The bill is formed into a curve that returns to a closed position, allowing for a tighter seal in backflow applications. An increased bill area also allows for a tighter seal, particularly at low flow rates.
- The flat bottom and offset design of the TF-1 allows it to be installed without modifications to structures such as interceptors, manholes and vaults where the invert of the pipe is close to the floor.
- The TF-1 is custom engineered in various constructions so that the valve can handle various backpressure with minimal headloss.
- The TF-1 is ideal for sewer systems and stormwater because it will seal around small debris. The TF-1 design is available with a slip-on or flanged pipe connection. Tideflex® TF-1 valves are constructed with a curved bill as standard in sizes 18" and larger.

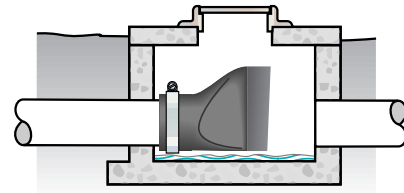

10

Series TF-1

Pipe O.D. (A)	Length (L)	Bill Height (H)	Cuff Length (C)
4	10	8	1 1/2
5	10	8	1 1/2
6	16	12	2
8	18	16	2
10	23	19	3
12	28	23	4
14	30	27	4
16	35	30	5
18	37	34	6
20	45	37	8
22	45	37	8
24	49	44	8
26	49	44	8
28	49	44	8
30	58	55	9
32	62	59	10
36	68	70	10
38	68	70	10
40	68	70	10
42	68	73	10
44	68	73	10
48	74	81	10
50	74	81	10
54	79	90	12
58	79	90	12
60	82	94	14
68	82	94	14
72	104	120	16
84	104	120	16
90	112	145	16
96	112	145	16

Dimensions are subject to change due to customized construction.

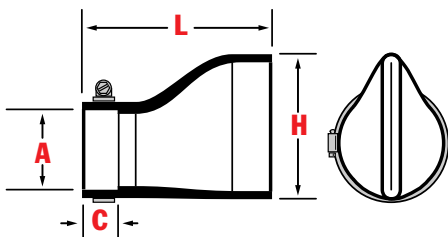

TF-1 Curved Bill Engineered Spine to handle long-term water weight

Cantilever spine of the TF-1 supports greater weight than TF-2 design.

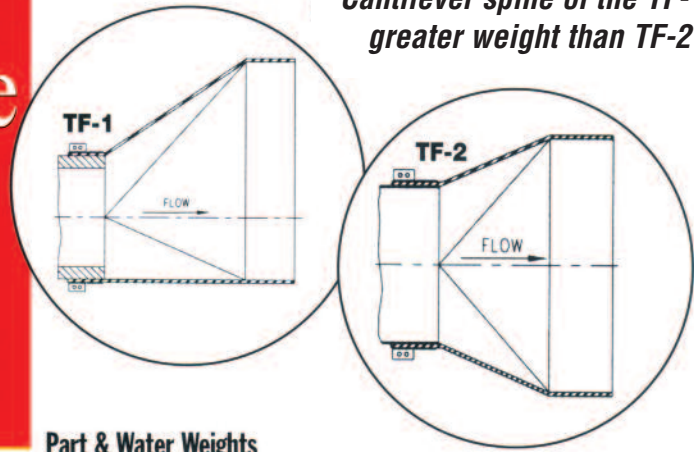

Since the spine of the TF-1 is at a greater vertical angle compared to the TF-2, the TF-1 is stronger at withstanding the cantilever effect when water is flowing through the valve.



The spine of the TF-1 is at a greater angle, reducing the cantilever effects of water weight.

Part & Water Weights

SIZE INCHES	TF-2/TF-1 WEIGHT POUNDS	WATER WEIGHT POUNDS	TOTAL WEIGHT POUNDS	TOTAL WEIGHT TONS
24	130	637	767	0.3
30	220	1072	1292	0.6
32	300	1380	1680	0.7
36	560	1801	2361	1.1
42	800	2702	3502	1.6
48	1027	3855	4882	2.2
60	1660	7556	9216	4.1
72	2620	13968	16588	7.4
84	3880	18411	22291	10.0
90	4664	23030	27670	12.4

11

TF-1 Curved Bill Less Bottom Clearance

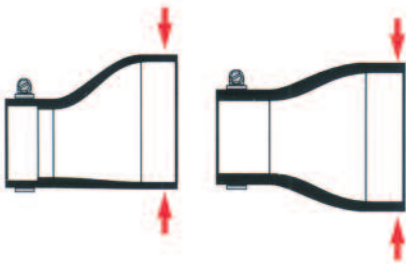

Both the TF-1 and TF-2 have the same bill height. The TF-1, however, flares at the top only. The bottom remains horizontal and does not flare downward. Therefore, not as much bottom clearance is required.

Bottom Clearance Required

SIZE	TF-1	TF-2
12	2	6
24	3	9.5
36	4	16.5
48	5	20
72	7	29.5
90	9	34.5

Chart indicated in inch-

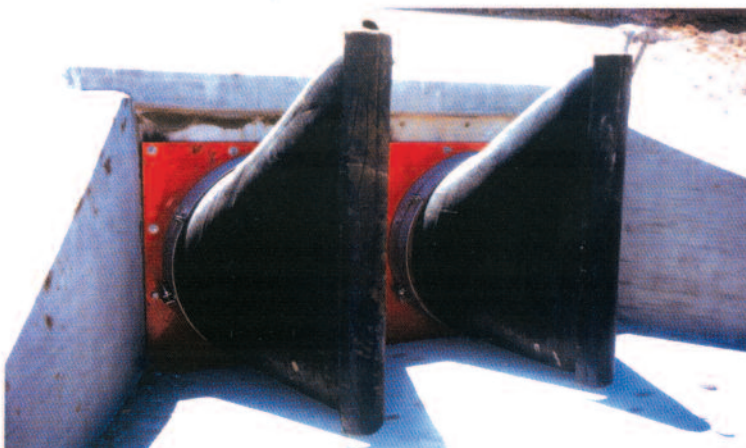

The TF-1 is ideal for sewer systems because it will seal around small debris. The TF-1 design is available with a slip-on or flanged pipe connection. Tideflex® TF-1 Valves are constructed with a curved bill as standard.

Ideal for manholes because influent pipes are close to the bottom of the vault. The TF-1 requires minimal bottom clearance compared to

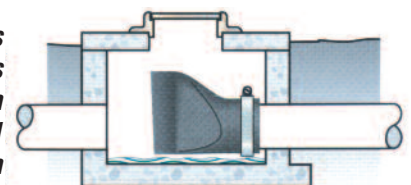

Series 35-1

- ▶ Eccentric flat bottom design
- ▶ Integral, all-rubber flange
- ▶ Lightweight, all-elastomer design
- ▶ Shorter length in sizes 42" and larger

Materials of Construction

Neoprene, Hypalon®, Buna-N, EPDM, Viton®

Backup Rings

Galvanized or stainless steel

The flat-bottom Series 35-1 features an integral rubber flange, allowing it to be mounted to flanged outfall pipes or directly to headwalls where the pipe is flush.

The flange size drilling conforms to ANSI B 16.10, Class 150#, or can be constructed with DIN, 2632 and other standards. The Series 35 Check Valve is furnished complete with steel or stainless steel backup rings for installation.

The Series 35-1 is often a direct replacement for flanged flapgates. Hinge pins rust and corrode if not routinely lubricated, causing the flapper to hang open and allow backflow. Small debris that collects in the seating area of the valve will also keep the flapper open. Tideflex® Series 35-1 valves 18" and larger are constructed with a curved bill as standard.

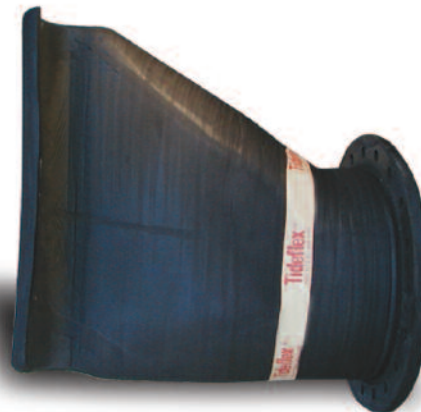

Series 35-1

Series 35-1

Flange Size (ANSI)	Flange O.D. (F)	Length (L ²)	Bill Height (H ²)
4	9	10	8
5	10	10	8
6	11	16	12
8	13 1/2	18	16
10	16	23	19
12	19	28	23
14	21	30	27
16	23 1/2	35	30
18	25	40	34
20	27 1/2	48	37
24	32	52	44
30	38 3/4	62	55
32	41 3/4	66	59
36	46	72	70
42	53	69	73
48	59 1/2	75	81
54	66 1/4	79	90
60	73	82	94
72	86 1/2	95	120

Dimensions are subject to change due to customized construction.

12

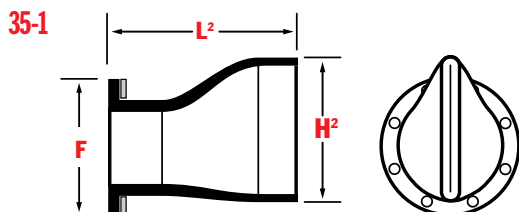

Series TF-2 / Series 35

- ▶ 100% elastomer construction
- ▶ Will not rust or corrode
- ▶ Will not warp or freeze open or shut
- ▶ Custom-built to customer specifications
- ▶ Low cracking pressure, low headloss
- ▶ Eliminates backflow

Materials of Construction:
Neoprene, Hypalon®, Buna-N, EPDM, Viton®

Mounting Bands:
304 or 316 Stainless Steel

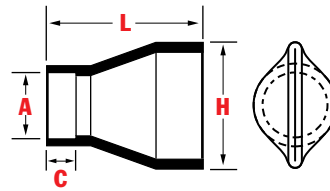
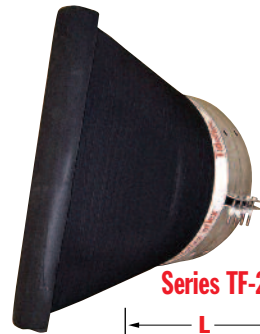

Series TF-2

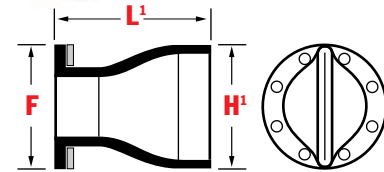

Series 35

The Tideflex® Series TF-2 and Series 35 Check Valves offer low cracking pressure to eliminate standing water. They have very low headloss that is not affected by rust, corrosion or lack of lubrication. The TF-2 and 35 are cost-effective because they require no maintenance or repairs. They have a long operational life span. The check valves operate using line pressure and backpressure to open and close, so no outside energy source is required.

The TF-2 and 35 are excellent replacements for ineffective metal flapgate valves because they will not warp or freeze and are virtually maintenance free.

The inside diameter of the TF-2's cuff is constructed to exactly match the outside diameter of the pipe.

The Series TF-2 is designed to slide onto the pipe O.D. and is held in place with clamps. The Series 35 is designed with integral flanges. Tideflex® TF-2 and Series 35 valves are constructed with a curved bill as standard in sizes 18" and larger.

Pipe O.D. (A)	Length (L)	Bill Height (H)	Cuff Length (C)
1/2	3	1 1/2	1/2
3/4	3	2	1
1	4	2	1
1 1/2	7	4	1
2	6	4	1
3	9	6	1 1/2
4	12	7	1 1/2
5	16	9	2
6	16	11	2
8	17	13	2
10	23	17	3
12	27	21	4
14	26	22	4
16	28	27	5
18	31	27	6
20	35	33	8 1/2
22	37	33	8
24	43	39	8
26	43	39	8
28	43	39	8
30	46	50	9
32	48	54	10
36	50	62	10
38	50	62	10
40	50	62	10
42	61	74	10
44	61	74	10
48	68	81	12
50	68	81	12
54	80	100	12
58	80	100	12
60	80	101	15
68	80	101	15
72	105	120	17
84	101	116	18
90	113	124	17
92	113	124	17
96	113	124	17

Flange Size (ANSI)	Length (L¹)	Bill Height (H¹)	Flange O.D. (F)
1/2	3	1 1/2	3 1/2
3/4	3	2	3 7/8
1	4	2	4 1/4
1 1/2	7	4	5
2	6	4	6
3	9	6	7 1/2
4	12	7	9
5	16	9	10
6	16	11	11
8	17	13	13 1/2
10	23	17	16
12	27	21	19
14	26	22	21
16	28	27	23 1/2
18	31	27	25
20	35	33	27 1/2
22	37	33	29 1/2
24	43	39	32
30	46	50	38 3/4
36	50	61	46
42	56	71	53
48	61	78	59 1/2
54	74	97	66 1/4
60	74	97	73
72	95	115	86 1/2

13

Dimensions are subject to change due to customized construction.

Series 37

- ▶ Installs between pipe flanges, eliminating valve body
- ▶ Offers minimal face-to-face dimension - only the thickness of the flange
- ▶ Features unique, maintenance-free, one-piece elastomer check sleeve design
- ▶ Eliminates chatter - silent, non-slamming
- ▶ Closes on entrapped solids

Materials of Construction:

- ▶ Valves are available in pure gum rubber, Neoprene, Hypalon®, Buna-N, Viton® and EPDM
- ▶ ANSI Class 125 Flanges, DIN PN6, PN10, PN16
- ▶ Special coating available



14

Tideflex® Technologies' Series 37 Flanged Inline Check Valve is a simple, reliable and cost-effective solution to backflow problems. Designed to be installed between two mating flanges, the Series 37 eliminates the need for a valve body.

With only one moving part, the maintenance-free rubber check sleeve, the Series 37 Inline Check Valve is simple in design. Sliding, rotating, swinging and spring parts are eliminated. There are no seats to corrode or packing to maintain. In addition, the Series 37 is a passive design that requires no external source of air or electricity to operate. The result is reduced operating costs.

The Series 37 Inline Check Valve can be ordered in a variety of elastomers. Flanges conform to ANSI B16.1 Class 125 specifications. Special custom designs or metric flanged models are also available. When ordering, specify line pressure, backpressure and whether an SST is required.

The pressure drop of the Series 37 is increased because of the smaller I.D. required to fit the check valve in the line.

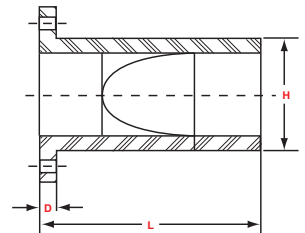
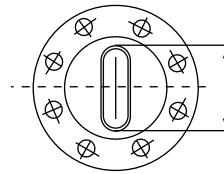

Dimensions Series 37 Flanged Inline Check Valve

Nominal Size* (Pipe I.D.)	Length L	Height of Bill H	Flange Thickness D	Max. Backpressure (psi)	
				Standard Tideflex®	With Saddle Support
2	5	1 7/8	3/8	150	CONTACT FACTORY
3	5 1/2	2 7/8	3/8	100	
4	7	3 7/8	3/8	75	
6	11	5 7/8	3/8	75	
8	12 1/2	7 7/8	1/2	60	
10	15 1/2	9 7/8	1/2	45	
12	18 1/2	11 7/8	1/2	35	
14	22	13 3/4	5/8	25	
16	23	15 3/4	3/4	20	
18	24	17 3/4	1	15	
20	32	19 3/4	1	10	
24	37	23 3/4	1	10	
30	41	29 3/4	1 1/2	8	
36	47	35 3/4	1 1/2	8	
42	49	41 1/2	1 3/4	5	
48	52	47 1/2	1 3/4	5	
54	57	53 1/2	2	5	
60	64	59 1/2	2	5	
72	73	71 1/2	2	5	

Dimensions are subject to change due to customized construction.
* Larger sizes available upon request.

Series 37G

- ▶ Fits inside pipe I.D.
- ▶ Fastened with internal expansion clamp
- ▶ Features all-elastomer, maintenance-free design
- ▶ Is custom-built to customer specifications
- ▶ Closes on entrapped solids

Materials of Construction:

- ▶ Valves are available in pure gum rubber, Neoprene, Hypalon®, Buna-N, Viton® and EPDM
- ▶ Stainless steel expansion clamps

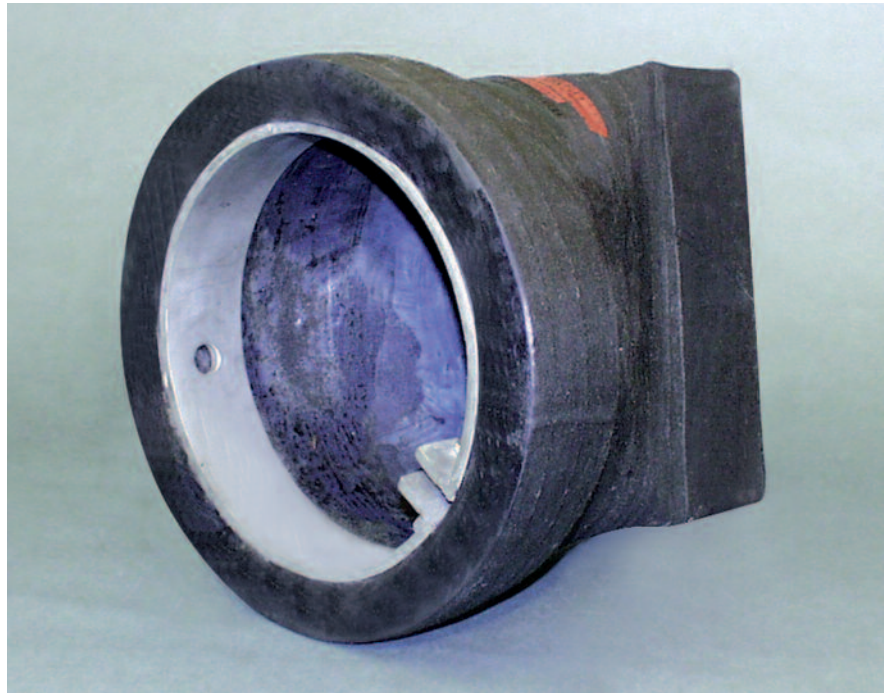

The Series 37G Inline Check Valve was developed specifically for installations where clearance below the invert of a pipe is insufficient to clear the flange of the standard Series 37. The 37G effectively has a zero face-to-face dimension since it can be completely slipped into an existing pipe. Piping modifications are not required to provide space for the valve. The Series 37G design uses the slip-on principle in reverse.

A special clamp that expands outward is provided to secure the valve to the inside of a pipe, enabling the valve to be installed easily on the outlet pipe from a manhole, such as in a CSO system.

The pressure drop of the Series 37G is increased because of the smaller I.D. required to fit the check valve in the line. Tideflex® Technologies recommends the valves be pinned to the pipe. Each clamp has four pre-drilled holes to allow installation of anchors/bolts. Contact our engineering staff for additional information.

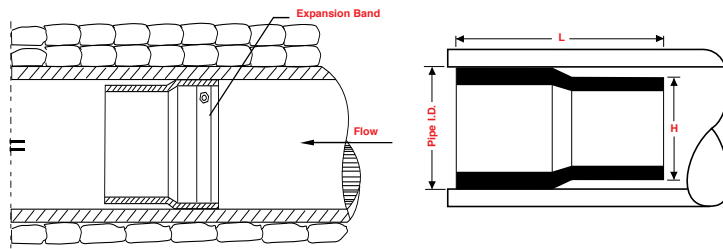

Dimensions Series 37G Check Valve

Nominal Size* (Pipe I.D.)	Length L	Height of Bill H	Max. Backpressure (psi)	
			Standard Tideflex®	With Saddle Support
2	5	1 7/8	150	CONTACT FACTORY
3	5 1/2	2 7/8	100	
4	7	3 7/8	75	
6	11	5 7/8	75	
8	12 1/2	7 7/8	60	
10	15 1/2	9 7/8	45	
12	18 1/2	11 7/8	35	
14	22	13 3/4	25	
16	23	15 3/4	20	
18	24	17 3/4	15	
20	32	19 3/4	10	
24	37	23 3/4	10	
30	41	29 3/4	8	
36	47	35 3/4	8	
42	49	41 1/2	5	
48	52	47 1/2	5	
54	57	53 1/2	5	
60	64	59 1/2	5	
72	73	71 1/2	5	

Dimensions are subject to change due to customized construction.

Contact engineering staff to verify overall dimensions.

** Other sizes available; consult factory. Valves are also made for non-standard pipe I.D.'s.*

Series 39/33

- ▶ Features an all-elastomer, maintenance-free design - no hinges or seals to bind
- ▶ Resists abrasion and provides backflow prevention
- ▶ Can be mounted in any orientation
- ▶ Closes on entrapped solids

Materials of Construction:

- ▶ Cast iron ASTM A126 body.
- ▶ Check sleeves available in pure gum rubber, Neoprene, Hypalon®, Buna-N, Viton® and EPDM
- ▶ ANSI Class 125/150, DIN PN6, PN10, PN16
- ▶ Special coatings available



16

The Tideflex® Technologies Series 39 Inline Check Valve is designed to handle abrasive materials, sewage, sludge and other difficult slurries. The valve's operation is silent and non-slamming.

At the heart of the Series 39 is a fabric-reinforced elastomer check sleeve that provides through-flow at minimum pressure drop across the valve at all times. The Series 39 Inline Check Valve, provided with a clean-out port and two flush ports, has a cast iron body that is available with special coatings.

The valve has face-to-face dimensions which meet ANSI B16.10 specs. When ordering, specify line pressure, backpressure and if an SST is required.

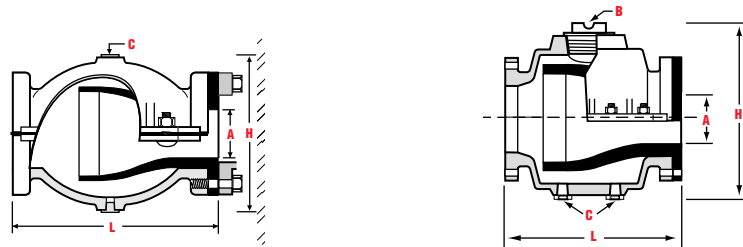

Dimensions Series 33 1"-3"

Valve Size A	Length L	Height H	Flush Connection C	Max. Backpressure (psi)	
				Standard Tideflex®	With Saddle Support
1	4 1/2	4 1/4	1/2	150	N/A
1 1/2	6 1/2	5	1/2	150	N/A
2	8 1/2	6 1/2	1/2	150	N/A
2 1/2	9 1/2	7	1/2	150	N/A
3	11 1/4	8	1/2	100	N/A

Dimensions Series 39 4"-24"

Valve Size A	Length L	Height H	Clean-Out Plug Diameter B	Flush Connection(s) C	Max. Backpressure (psi)	
					Standard Tideflex®	With Saddle Support
4	11 1/2	10 3/4	2	1 - 1	75	150
6	14	14	4	1 - 1	75	150
8	19 1/2	17 1/4	4	2 - 1	60	125
10	24 1/2	22 3/4	4	2 - 1	45	75
12	27 1/2	24 3/4	4	2 - 1	35	75
14	31	27 3/4	4	2 - 1	25	70
16	34	31 1/4	4	2 - 1	20	60
18	38 1/2	35	6" Flanged	2 - 1	15	45
20	40	42 3/4	6" Flanged	2 - 1	10	40
24	51	45 1/2	6" Flanged	2 - 1	10	40

Dimensions are subject to change due to customized construction.

Series 39F

- ▶ Features fabricated large-diameter design
- ▶ Provides maintenance-free operation - no hinges to bind or freeze
- ▶ Can be mounted in any position
- ▶ Closes on entrapped solids

Materials of Construction:

- ▶ Check sleeves available in pure gum rubber, Neoprene, Hypalon®, Buna-N, Viton® and EPDM
- ▶ Fabricated steel ASTM A285 grade C or stainless steel 304SS ASTM A240 or 316SS ASTM A240
- ▶ ANSI Class 125/150 flanges, DIN, PN6, PN10, PN16
- ▶ Special coating available

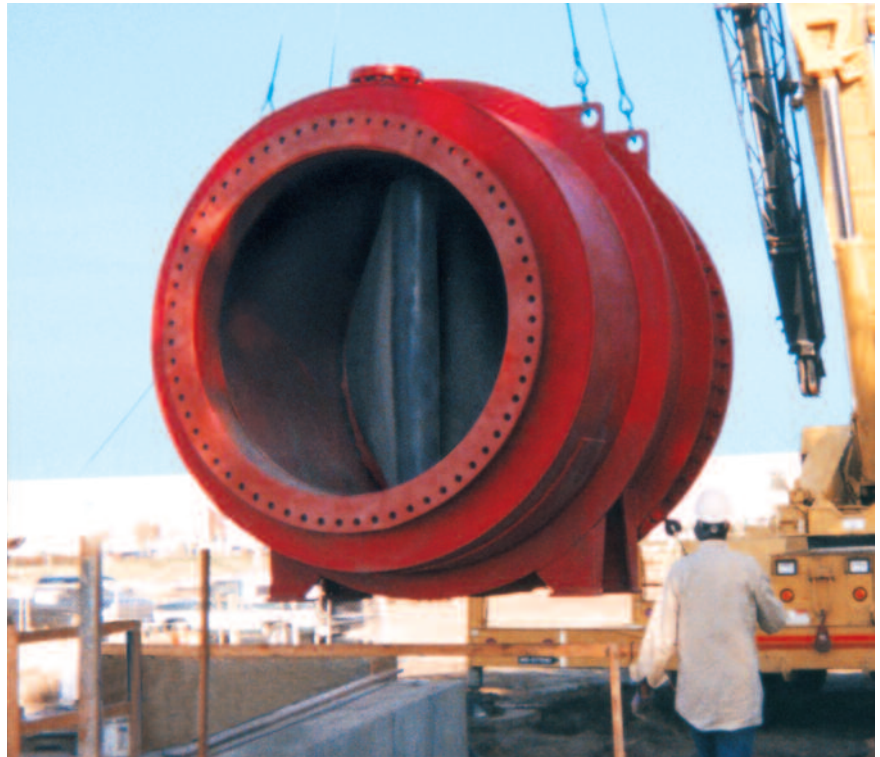

17

The Tideflex® Technologies Series 39F Fabricated Inline Check Valve is designed to handle abrasive material, sewage, sludge and other difficult slurries. The heart of the valve is the Tideflex® Check Sleeve that provides through-flow at minimum pressure drop across the valve at all times. Forward pressure opens the valve automatically; reverse pressure seals the valve. The valve's operation is silent and non-slaming.

The inner rubber check valve minimizes wear and deterioration caused by continuous operation of abrasive slurries. There are no mechanical parts such as hinges, disks or metal seats that can freeze, corrode or bind valve operation.

The steel-fabricated valve body is designed to provide easy installation or replacement of a standard Tideflex® Check Valve.

The Series 39F Fabricated Inline Check Valve is provided with an inspection port and bottom flush ports.

The valve flanges are drilled for through-bolting; face-to-face dimensions meet ANSI B16.10 specs. When ordering, specify line pressure, backpressure and whether an SST is required.

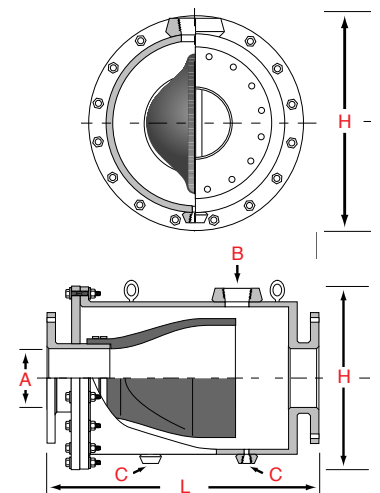

Dimensions Series 39F Fabricated Body

Valve Size A	Length L	Height H	Clean-Out Plug Dia. B	Flush Port Diameter C	Max. Backpressure (psi)	
					Standard Tideflex®	With Saddle Support
30	60	66	6	1	8	40
36	77	77	6	1	8	35
42	80	90	6	1	5	25
48	90	102	6	1	5	25
54	105	126	6	1	5	20
60	110	126	6	1	5	15
72	123	144	6	1	5	15
84	126	119	6	2	5	15

Dimensions are subject to change due to customized construction.

Series 4739

- ▶ Economical lightweight design for low pressure
- ▶ Elastomer check valve resists abrasion and provides backflow prevention
- ▶ No hinges or seats to bind or freeze
- ▶ A maintenance-free design
- ▶ Can be mounted in any position
- ▶ Silent, non-slamming - eliminates chatter

Materials of Construction:

- ▶ Spun aluminum body
- ▶ Galvanized steel back up rings
- ▶ Check sleeves available in pure gum rubber, Neoprene, Hypalon®, Chlorobutyl, Buna-N, EPDM and Viton®

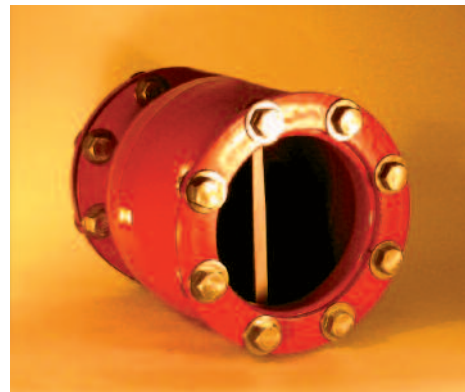

The Tideflex® Series 4739 Check Valve is manufactured with a spun aluminum body. The check valve is designed to handle water, sewage, sludge, lake water and most hydraulic flows.

The heart of the Series 4739 check valve is a Tideflex® fabric-reinforced elastomer check sleeve which allows flow at minimum pressure drop across the valve at all times. Forward pressure opens the valve automatically and reverse pressure seals the valve.

The Series 4739's unique elastomer check valve has the ability to seal around small pebbles, sticks, leaves and other debris.

Wear and deterioration caused by continuous operation is minimized because of the inner elastomer check valve. There are no mechanical parts such as hinges, discs or metal seats that can freeze, corrode or bind. The valve's operation is silent and non-slamming.

This low pressure, economical design is ideal for systems with less than 50' of head. Special coatings or strap-on end of pipe designs are available.

Dimensions Series 4739 Check Valve

VALVE SIZE D	LENGTH F-to-F	BODY WIDTH A	MAXIMUM BACK PRESSURE (psi)
2" (50mm)	7"	6"	40
3" (75mm)	8"	7-3/4"	40
4" (100mm)	9"	9-1/4"	30
6" (150mm)	12"	11-1/4"	20
8" (200mm)	16"	13-3/4"	20
10" (250mm)	30"	18"	15
12" (300mm)	35-3/4"	20-1/4"	15

Flange Drilling: ANSI 150, DIN and BIS, AUS available.

18

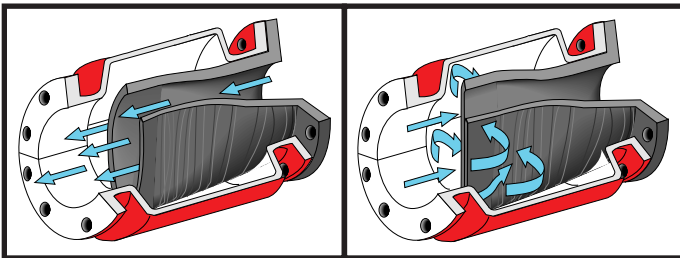

The Series 4739 Tideflex® Check Valve opens with positive pressure. Reverse pressure seals the bill of the valve to prevent backflow.

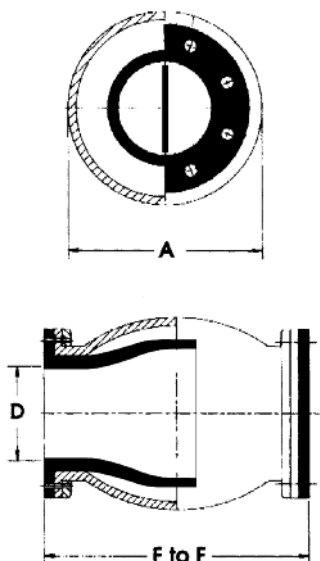

Series 2633

- ▶ Eliminates check valve chatter
- ▶ Can be mounted in any position
- ▶ Is ideal for pneumatic systems
- ▶ Closes on entrapped solids

Materials of Construction:

- ▶ Steel, stainless steel or PVC body
- ▶ Steel, stainless steel or PVC end connections
- ▶ Check sleeves available in pure gum rubber, Neoprene, Hypalon®, Buna-N, Viton® and EPDM



Manufactured on the same principle as Tideflex® Technologies' revolutionary all-rubber Tideflex® Inline Check Valve, the Series 2633 is a simple inline check valve for threaded end pipelines.

Simple in design, the Series 2633 consists of a body, two endcaps and an elastomer check sleeve. In the open position, the sleeve creates a wide, free passage proportional to the flow in the pipeline. On flow reversal, the sleeve closes slowly and completely.

The silent, non-slamming Series 2633 Inline Check Valve design eliminates water hammer and facilitates low headloss. Containing no levers, balls, floats or springs to corrode, the valve is virtually maintenance-free. The only replacement part is the simple, rugged elastomer check sleeve.

This small and simple inline check valve is ideal for liquids, gases, powders, slurries and instrument or plant air as well as in any environment where preventing backflow is required.

The Series 2633 is manufactured in sizes 1/2" to 3". The check sleeve is available in a variety of elastomers to match specific service conditions.

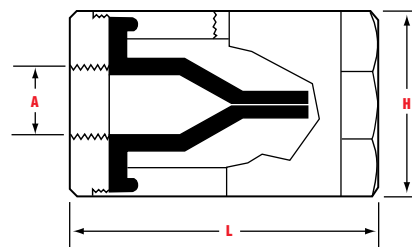

Dimensions Series 2633 Small Diameter InLine Check Valve

Valve Size A	Length L	Body O.D. H	Weight Steel (lbs.)	Max. Back- pressure (psi)*
1/2	4 1/2	2 3/4	3	75
3/4	4 1/4	2 3/4	3	75
1	4 1/2	2 3/4	3	75
1 1/2	6 1/2	3 3/4	8	50
2	7 1/2	4	14	25
3	8 1/2	5	18	25

Dimensions are subject to change due to customized construction.

** Saddle Support Technology not available for 2633.*

Tideflex® Coarse Bubble Diffusers:

- ▶ Optimize oxygen transfer and mixing characteristics
- ▶ Provide proven long-term, maintenance-free service life
- ▶ Provide reliable backflow prevention
- ▶ Prevent clogging and fouling - no jet wash or acid baths required
- ▶ Offer durable, heavy-duty construction

20

Proven Performance On:

- ▶ Aeration basins
- ▶ Sludge-holding tanks
- ▶ Equalization basins
- ▶ Aerated grit chambers
- ▶ Pre-/post-aeration processes
- ▶ Channels
- ▶ Aerobic digesters
- ▶ Flocculation
- ▶ Storage tanks
- ▶ Landfill odor control systems
- ▶ Industrial mixing systems

Problem



Solution



Providing optimal oxygen transfer and mixing characteristics with reliable backflow prevention, Tideflex® Diffusers are ideal for use in municipal and industrial aeration applications. While conventional fine and coarse bubble diffusers typically clog with sludge when airflow is interrupted due to blower shutdown or power failure, Tideflex® Coarse Bubble Diffusers maximize mixing while totally isolating the wastewater from the air manifold and related equipment and instrumentation. By allowing routine shutdowns and eliminating the need to run blowers or compressors around the clock to prevent clogging of the diffusers and manifold, Tideflex® Diffusers provide substantial savings in energy and operational costs.

The principle of operation is simple. Positive differential air pressure opens the Tideflex® Diffuser, allowing airflow. Reverse pressure on the outside of the diffuser seals the bill, preventing backflow of solids or liquids. The patented elastomeric design closes drop-tight, even sealing around entrapped solids, eliminating any concern of clogging commonly associated with conventional air diffuser systems as well as the extensive costs required to maintain, repair and clean them.

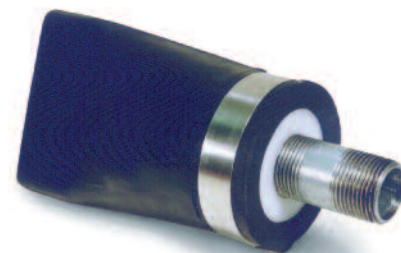

TF-A diffusers are ideal for new and retrofit systems available with 1/2" and 3/4" thread connectors or slip-on connection.



The Tubeflex® Fine Bubble Air Diffuser features a built-in Tubeflex® that eliminates plugging of the header pipe. The hollow-core design reduces buoyancy.

Water Mixing System



3MG ground level steel reservoir, with TMS inlet nozzles.

Tideflex® Mixing Systems for Reservoirs

The Tideflex® Mixing System (TMS) improves water quality within potable water storage systems in three important ways. First, by separating the inlet and outlet to opposite sides of the tank or reservoir, the TMS eliminates the short-circuiting created by a single inlet/outlet. This ensures a complete turnover of the water within the tank to eliminate stagnation.

Second, the TMS ensures that the contents of the storage tank or reservoir remain in a completely mixed state, by increasing the jet velocity of the influent. Tideflex® valves are inherently variable orifice valves, opening and closing in proportion to the amount of flow. This reduces the fill time required to achieve complete mixing.

Finally, each TMS is individually designed and engineered for its specific application. The location and number of inlets and outlets can be adjusted to reduce or eliminate dead zones. Extensive Computational Fluid Dynamic (CFD) modeling of various tank styles provides Red Valve with the optimal configuration.

The TMS is totally passive, requiring no additional energy source. Because it is housed completely within the reservoir, the TMS requires no additional external piping runs or tank penetrations.



TMS inlet nozzles.



Outlet valves for high volume draining.

Proven Performance On:

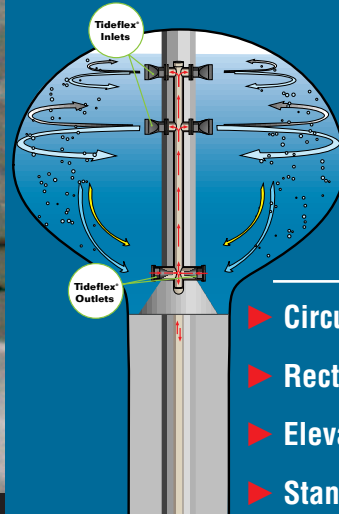

- ▶ Circular reservoirs
- ▶ Rectangular reservoirs
- ▶ Elevated storage tanks
- ▶ Standpipes

21

Tideflex® Mixing System:

- ▶ NSF approved
- ▶ Prevents short-circuiting to avoid stagnation
- ▶ Increase jet velocity to improve mixing
- ▶ Optimize inlet/outlet design to eliminate dead zones
- ▶ Can be used with recirculation and rechlorination systems
- ▶ Operates on differential pressure; no external energy source required
- ▶ Can be designed for new and retrofit applications, standpipes and elevated tanks

Tideflex® Effluent Diffuser Valves:

- ▶ Prevent intrusion of debris, sediment, saltwater and aquatic life
- ▶ Provide proven long-term, maintenance-free service life
- ▶ Enhance jet velocity
- ▶ Improve initial dilution
- ▶ Provide a more uniform flow distribution across ports
- ▶ Promote significant improvement in saltwater purging



(12) 6" Tideflex® Diffuser Valves with integral three-foot-long rubber risers discharging to a shallow river.

22

Proven Performance On:

- ▶ Marine outfalls
- ▶ Inland outfalls
- ▶ Retrofit outfall pipelines



PROBLEM



SOLUTION

Engineered Design and Technical Analysis for Effluent Diffuser Systems

Tideflex® Effluent Diffuser Valves are used to prevent intrusion of unwanted sand, sediment, saltwater and marine growth into outfall pipelines. The unique design of the valve also greatly improves the performance of the diffuser system by increasing mixing and dispersion through increased velocity.

Tideflex® Technologies offers complete engineering and design support for effluent diffuser outfalls and has developed an exclusive computer program to assist engineers in designing multipoint diffusers. The program includes data analysis of headloss, totalheadloss, jet velocity and effective open area. This data can be compared to conventional fixed-orifice diffuser designs to illustrate the hydraulic advantages of Tideflex® Effluent Diffuser Valves.

Also available for individual Tideflex® Diffuser Valves are graphs of headloss, total headloss, jet velocity and effective open area organized in a "4-pack" format.

For a diffuser nozzle hydraulics analysis, please contact our engineering department.

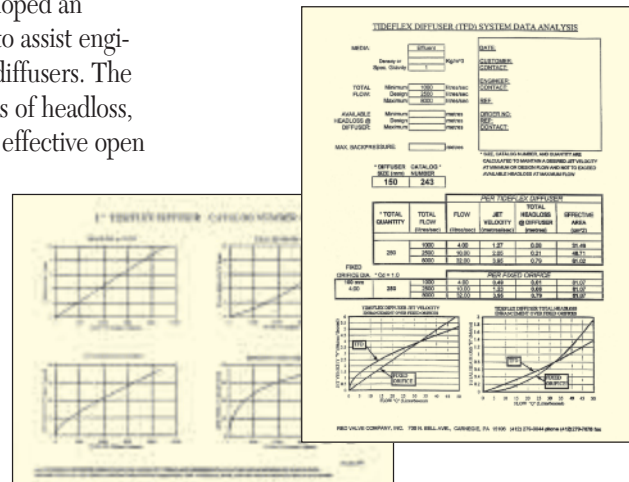

Waterflex® Check Valve



- ▶ High backpressure rating
- ▶ Seals drop-tight, eliminating backflow
- ▶ No springs, packing or seals
- ▶ Lightweight
- ▶ Non-slamming
- ▶ Low profile, short face-to-face
- ▶ Easy to install



This 84" Waterflex was installed in the inlet tower of an 1100 acre reservoir.

The Waterflex® Check Valve is an entirely new valve design from Tideflex® Technologies, specifically engineered for potable water applications. The all-new Waterflex® provides low headloss characteristics and features high backpressure ratings comparable to other valve styles, such as lever-and-weight or spring-loaded disks.

The elastomer Waterflex® is more cost-effective than other valve styles. Moving parts, such as hinges and springs, can seize if routine maintenance and lubrication are not performed. The Waterflex® has no moving parts that require maintenance or repairs. Operational costs are low and service life is long.

23

**Headloss vs. Pipe Velocity
WF-1 Style**

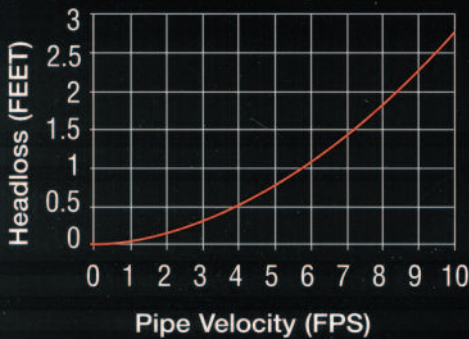

**Headloss vs. Pipe Velocity
WF-2 and WF-3 Styles**

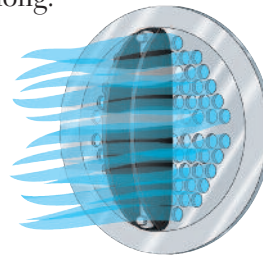
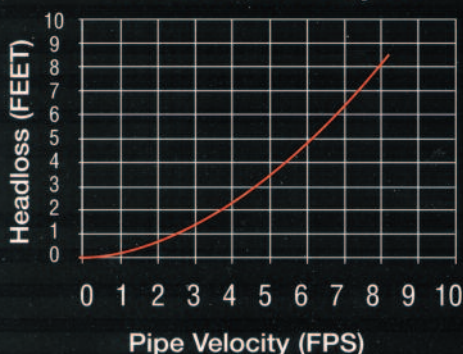

Forward hydraulic pressure folds the elastomer disk away from the perforated plate, allowing flow.

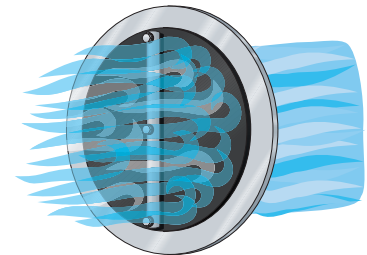

Reverse pressure seals the elastomer disk against the plate, preventing backflow.



ANSI Flange Size	Plate Thickness	WF-2 Wafer O.D.	WF-3 Flanged I.D.	Pressure Rating psi
4"	0.25"	6.19"	9"	150
6"	0.25"	8.50"	11"	150
8"	0.38"	10.63"	13.5"	150
10"	0.38"	12.75"	16"	150
12"	0.50"	15"	19"	150
16"	0.75"	18.5"	23.5"	150
24"	1.00"	27.25"	32"	150
30"	1.00"	34.5"	38.75"	150
36"	1.00"	41"	46"	150
42"	1.25"	47.75"	53"	150
48"	1.25"	54.25"	59.50"	150

For sizes 54" and larger, contact factory.

Tideflex® Technologies



Tideflex® Check Valves

The best check valve in the world replaces high maintenance flapgates to ensure reliable backflow prevention on stormwater, effluent and CSO outfalls. Available in sizes to 96". For more detail, see pages 3-13.



Tideflex® Inline Check Valves

Designed with the Tideflex® Check Valve, the Series 39, 39F, 4739 and 4739-R, provide maintenance-free backflow prevention. Available in sizes to 96". For more detail, see pages 14-19.



Tideflex® Aeration Systems

Tideflex® Diffused Aeration Systems utilize backflow prevention technology to provide a maintenance-free system. Fine bubble, coarse bubble and combination aeration systems available. For more detail, see page 20.

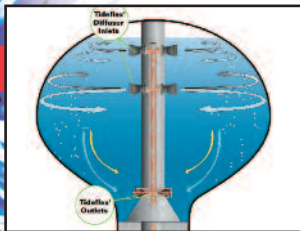

Tideflex® Reservoir Mixing Systems

The Tideflex® Mixing System improves water quality in finished water storage tanks and reservoirs of any size or style. The custom engineered systems prevent short-circuiting, stagnation, thermal stratification and optimize mixing. For more detail, see page 21.



Tideflex® Effluent Diffuser Systems

Tideflex® Effluent Diffusers prevent intrusion of debris, sediment, saltwater and aquatic life into outfall lines while optimizing diffuser hydraulics. For more detail, see page 22.



Waterflex® Check Valves

The unique wafer-thin elastomer Waterflex® Check Valve provides reliable backflow prevention with no moving parts that require maintenance or repairs. Available in sizes to 96". For more detail, see page 23.



600 N. Bell Ave., Carnegie, PA 15106 USA Phone: 412.279.0044 Fax: 412.279.7878 www.tideflex.com

The information presented in this catalog is provided in good faith. Tideflex® Technologies reserves the right to modify or improve its design specifications without notice and does not imply any guarantee or warranty for any of its products from reliance upon the information contained herein. All orders are subject to Tideflex® Technologies' standard terms and warranty and are subject to final acceptance by Tideflex® Technologies.

Tideflex® is a registered trademark of Red Valve Company, Inc.

The products contained in this brochure are covered under one of the following patent numbers: United States - 5,606,995; 5,727,593; 5,769,125; 5,931,197; 6,016,839; 6,193,220; 6,367,505; 6,367,783; 6,372,140; 6,412,514; 6,585,005; 6,702,263; 6,953,059; 7,104,279. Canada - 2,247,489; 2,316,287; 2,366,252; 2,366,605; 2,385,902. U.K. - 2,329,453.



TF 0411